

B1060S

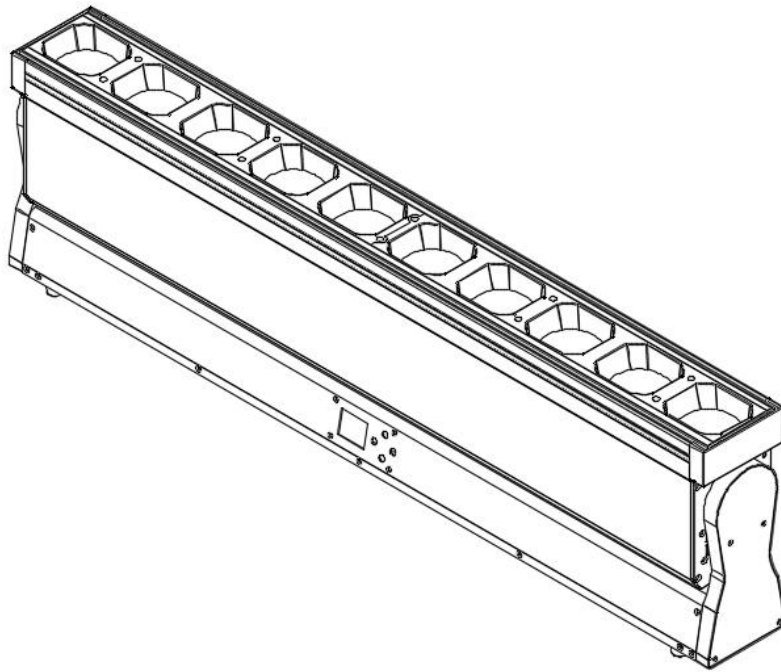

Manual

1.Safety Instructions

Please keep this User Guide for future consultation. If you sell the unit to another user, be sure that they also receive this instruction manual.

Unpack and check carefully to ensure that there is no transportation damage before using the unit.

This product is for indoor use only. Use only in a dry location.

DO install and operate by qualified operator.

Use safety chain when fixing the unit. Handle the unit by carrying its base instead of head only.

The unit must be installed in a location with adequate ventilation, at least 50cm from adjacent surfaces.

Be sure that no ventilation slots is blocked, otherwise the unit will be overheated.

Before operation, ensure that you are connecting this product to the proper voltage in accordance with the specifications in this manual or on the product's specification label.

It's important to ground the yellow/green conductor to earth in order to avoid electric shock.

Minimum ambient temperature TA: 0°C. Maximum ambient temperature TA: 40°C. Do not operate this product at a lower or higher temperature.

DO NOT connect the device to any dimmer pack.

Keep flammable materials away from the fixture while operating to avoid fire hazard.

Make sure the power cord is not crimped or damaged; replace it immediately if damaged.

Unit's surface temperature may reach up to 75 C. DO NOT touch the housing bare-handed during its operation.

Avoid any flammable liquids, water or metal from entering the unit. Once it happens, cut

off the mains power immediately.

DO NOT operate in a dirty or dusty environment. DO clean the fixture regularly.

DO NOT touch any wire during operation as there might be a hazard of electric shock. Avoid entanglement of the power cord with other wires.

The minimum distance to objects/surface must be more than 0.5 meters.

Disconnect mains power before fuse replacement or servicing.

Replace fuse only with the same type.

In the event of serious operating problem, stop using the unit immediately.

Never turn on and off the unit time after time.

The housing, the lenses, or the ultraviolet filter must be replaced if they are visibly damaged.

DO NOT open the housing as there are no user serviceable parts inside.

DO use the original packaging if the device is to be transported.

2. INSTALLATIONS

3. DO install and operate by qualified operator. Fixtures should be installed in areas outside walking paths, seating areas, or away from areas where unauthorized personnel might reach the fixture by hand. NEVER stand directly below the fixture(s) when rigging, removing or servicing.

Always ensure that the unit is firmly fixed to avoid vibration and slipping off during operation. Ensure that the trussing or area of installation must be able to hold 10 times the weight without any deformation. Always attach a safety cable that can hold at least 12 times the weight of the fixture whenever installing this fixture in a suspended environment to ensure that the fixture will not fall if the clamp fails.

This fixture is fully operational in three different mounting positions: hanging upside-down, mounted sideways on trussing, or fix on a flat level surface (such as the ground or a wall). Always use and install the supplied safety cable as a safety measure to prevent accidental damage and/or injury in the event the clamp fails.

3. DMX-512 control connections

Connect the provided XLR cable to the female 3-pin XLR output of your controller and the other side to the male 3-pin XLR input of the moving head.

You can chain multiple

Moving heads be connected together through serial linking. The cable needed should be two core, screened cable with XLR input and output connectors.

For installations where the DMX cable has to run a long distance or is in an electrically noisy environment, such as in a discotheque, it is recommended to use a DMX terminator. This helps in preventing corruption of the digital control signal by electrical noise. The DMX terminator is simply an XLR plug with a 120 Ω resistor connected between pins 2 and 3, which is then plugged into the output XLR socket of the last fixture in the chain. Please see illustrations below

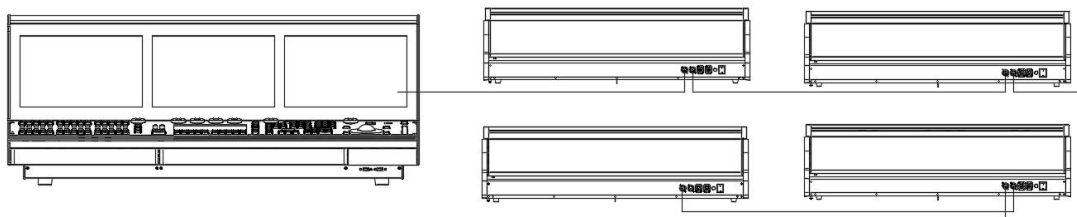
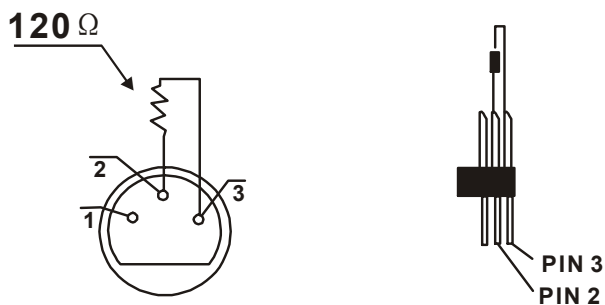
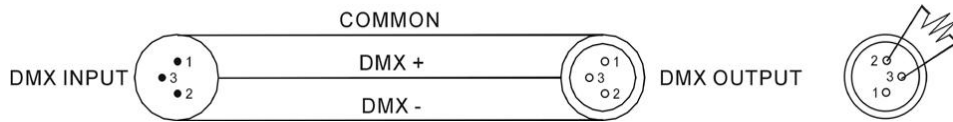

4.Address code setting

If you use a universal DMX controller to control the units, you have to set DMX address from 1 to 512 so that the units can receive DMX signal.

Press the MENU button to enter menu mode, select DMX Settings, press the ENTER button to confirm, use the UP/DOWN button to select DMX Address, press the ENTER button to confirm, the present address will blink in the display, use the UP/DOWN button to adjust the address from 001 to 512, press the ENTER button to store. Press the MENU button back to the last menu or let the unit idle 30 seconds to exit menu mode. Please refer to the following diagram to address your DMX512 channel for the first 4 units.

Channel MODE	UNIT1 ADDERSS	UNIT2 ADDERSS	UNIT3 ADDERSS	UNIT4 ADDERSS
17CH	1.1	1.18	1.35	1.52
27CH	1.1	1.28	1.55	1.82
99CH	1.1	1.100	1.199	1.298
108CH	1.1	1.109	1.217	1.325
168CH	1.1	1.169	1.337	2.1
170CH	1.1	1.171	1.341	2.1

5. Fixture size

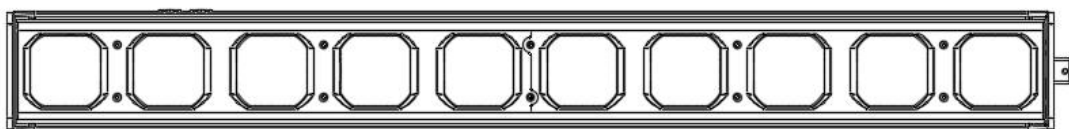
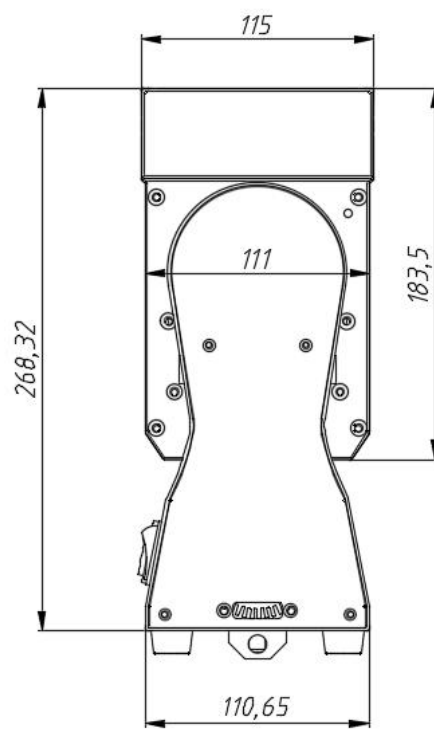
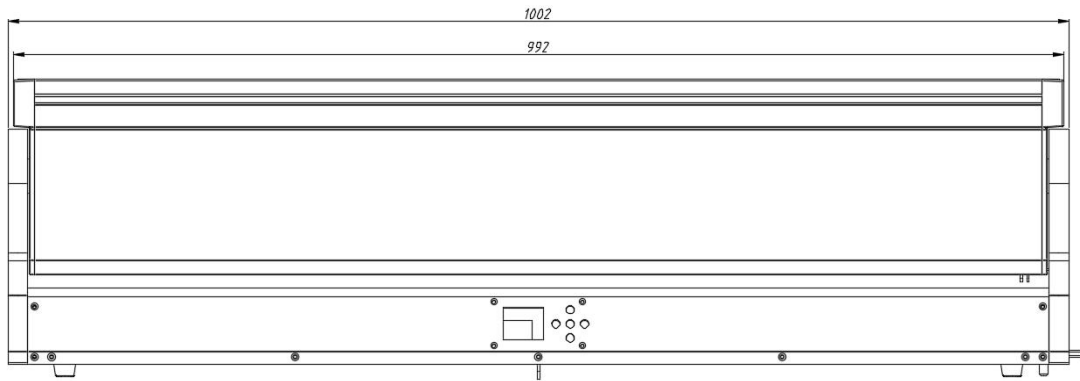

6.Parameter characteristics:

Input Voltage: 100-240V,50/60Hz

Total power: 800W

Main light source: 10x60W RGBW LED

Auxiliary light: 96X3W CW LED

:96X3W WW LED

:96X0.5W RGB LED

Channel : 17CH/27CH/99CH/108CH/168CH/170CH

Control mode: DMX512, Auto、Sound, Master/Slave

Zoom angle: 5~46 °

White temperature: 6500k

LED life: >20000 hours

Dimming: 0-100% linear dimming

Strobe:1-25Hz

10 main lights can be controlled by a single point

Auxiliary light CW/WW/RGB is independently controlled by 24 segments

Full and sharp beam with rich built-in effects

Power supply: power connector input/output

Signal input/output: Three core or five core XLR head

Y axis magnetic coding positioning is more accurate

Unique concealed splicing lock

Seamless splicing of lamps (all equidistant)

Size:1002x110x268mm

Features:

The B1060S is a multi-functional effect lamp that integrates light beam, stroboscopic and dyeing effects. When multiple lamps are seamlessly spliced, the light beam emitted by the equidistant LED can cover a wide area, and it is sharp and clear. The auxiliary light area uses LED light strips independently controlled by 12 areas on one side, which has the color mixing function.

7. Menu operation

Main Menu	Sub menu	description
Dmx Addre	Address	1-512
SET	Run mode	DMX/sound/Auto1/Auto2
	Channel mode	17CH/27CH/99CH/108CH /168CH/170CH
	Invert pixel	OFF/ON
	Invert tilt	OFF/ON
	Reserve	OFF/ON
	Encodre crct	OFF/ON
	Signal Keep	OFF/ON
	Screen Saver	OFF/ON
	Invert Screen	OFF/ON/Auto
	Update Slave	OFF/ON
	Language	中/EN
	Dimmer curve	curve1-4
	Dimmer speed	fast/smooth
		Load default
Manual	Manual control channel values	000-255
Calib	Enter password	6688
Reset	Focus motor reset	Only focus motor reset
	Y-axis reset	Y-axis reset only
	Reset all motors	Fixture reset
Note	Reset info	Display specific information content
	DMX Data detection	Display specific DMX detection content
	Sensor information	Display the specific information of optocoupler and Hall

	Hardware version	Display hardware version number
	Software version	Display software version number

option	explain
Reset error message	<p>If the red ERR indicator lights up, it indicates that the lamp is operating incorrectly:1)</p> <p>IC1 communication failure (communication failure between 6 lamp beads and display board)2)</p> <p>IC2 communication failure (communication failure between 4 lamp beads and display board)3)</p> <p>Y-axis error</p> <p>4) Reset failed</p>

8. DMX512

17CH

CH	Function	DMX value	explain
1	Y	0-255	0-270°
2	Y fine	0-255	16bit
3	Zoom	0-255	0-100%
4	dimmer	0-255	0-100%
5	Main light strobe	0-7	Close
		8-15	Open
		16-131	Strobe, from slow to fast
		132-139	Open
		140-181	Slow opening and fast closing, from slow to fast
		182-189	Open
		190-231	Open slowly, close slowly, from slow to fast
		232-239	Open
		240-247	Random strobe, from slow to fast
		248-255	Open
6	CW/WW strobe	0-7	Close
		8-15	Open

		16-131	Strobe, from slow to fast
		132-139	Open
		140-181	Slow opening and fast closing, from slow to fast
		182-189	Open
		190-231	Open slowly, close slowly, from slow to fast
		232-239	Open
		240-247	Random strobe, from slow to fast
		248-255	Open
7	RGB Strobe	0-7	Close
		8-15	Open
		16-131	Strobe, from slow to fast
		132-139	Open
		140-181	Slow opening and fast closing, from slow to fast
		182-189	Open
		190-231	Open slowly, close slowly, from slow to fast
		232-239	Open
		240-247	Random strobe, from slow to fast
		248-255	Open
8	function	0-29	No function
		30-39	Dimming curve: linear
		40-49	Dimming curve: square ratio
		50-59	Dimming curve: inverse square
		60-69	Dimming curve: S curve
		70-139	No function
		140-149	Y Reset
		150-159	Zoom reset
		160-199	No function
		200-209	ALL reset
		210-219	Dimming speed: fast
		220-229	Dimming speed: smooth
		230-255	No function

9	Main red	0-255	0-100%
10	Main green	0-255	0-100%
11	Main blue	0-255	0-100%
12	Main white	0-255	0-100%
13	CW	0-255	0-100%
14	WW	0-255	0-100%
15	Auxiliary light R	0-255	0-100%
16	Auxiliary light G	0-255	0-100%
17	Auxiliary light B	0-255	0-100%

27CH

CH	Function	DMX value	explain
1	Y	0-255	0-270°
2	Y fine	0-255	16bit
3	Zoom	0-255	0-100%
4	dimmer	0-255	0-100%
5	Main light strobe	0-7	Close
		8-15	Open
		16-131	Strobe, from slow to fast
		132-139	Open
		140-181	Slow opening and fast closing, from slow to fast
		182-189	Open
		190-231	Open slowly, close slowly, from slow to fast
		232-239	Open
		240-247	Random strobe, from slow to

			fast
		248-255	Open
6	CWWW Strobe	0-7	Close
		8-15	Open
		16-131	Strobe, from slow to fast
		132-139	Open
		140-181	Slow opening and fast closing, from slow to fast
		182-189	Open
		190-231	Open slowly, close slowly, from slow to fast
		232-239	Open
		240-247	Random strobe, from slow to fast
		248-255	Open
		7	RGB Strobe
8-15	Open		
16-131	Strobe, from slow to fast		
132-139	Open		
140-181	Slow opening and fast closing, from slow to fast		
182-189	Open		
190-231	Open slowly, close slowly, from slow to fast		
232-239	Open		
240-247	Random strobe, from slow to fast		
248-255	Open		
8	function	0-29	No function
		30-39	Dimming curve: linear
		40-49	Dimming curve: square ratio
		50-59	Dimming curve: inverse square
		60-69	Dimming curve: S curve
		70-139	No function
		140-149	Y Reset
		150-159	Zoom reset
		160-199	No function
		200-209	ALL reset

		210-219	Dimming speed: fast
		220-229	Dimming speed: smooth
		230-255	No function
9	Main red	0-255	0-100%
10	Main green	0-255	0-100%
11	Main blue	0-255	0-100%
12	Main white	0-255	0-100%
13	Main CTO	0	No function
		1-255	8000K-2500K
14	Main Color	0-7	No function
		8-255	Color selection
15	Main Effect	0-7	No function
		8-15	Effect1
		...	8 numerical values for one effect
		184-191	Effect23
		192-255	No function
16	Main Effect speed	0-127	From slow to fast (no fading effect)
		128-255	From slow to fast (fade out effect)
17	CW/WW CTO	0-67	No function
		68-247	6500K-2600K
		248-255	No function
18	CW	0-255	0-100%
19	WW	0-255	0-100%
20	CW/WW Effect	0-7	No function
		8-15	Effect1
		...	8 numerical values for one effect
		184-191	Effect23

		192-255	No function
21	CW/WW Effect speed	0-127	From slow to fast (no fading effect)
		128-255	From slow to fast (fade out effect)
22	Auxiliary light R	0-255	0-100%
23	Auxiliary light G	0-255	0-100%
24	Auxiliary light B	0-255	0-100%
25	Auxiliary light color	0-7	No function
		8-255	Color selection
26	Auxiliary light RGB Effect	0-7	No function
		8-15	Effect1
		...	8 numerical values for one effect
		184-191	Effect23
		192-255	No function
27	Auxiliary light RGB Effect speed	0-127	From slow to fast (no fading effect)
		128-255	From slow to fast (fade out effect)

99CH

CH	Function	DMX value	explain
1	Y	0-255	0-270°
2	Y fine	0-255	16bit
3	Zoom	0-255	0-100%
4	dimmer	0-255	0-100%
5	Main light strobe	0-7	Close
		8-15	Open
		16-131	Strobe, from slow to fast
		132-139	Open
		140-181	Slow opening and fast closing, from slow to fast
		182-189	Open

		190-231	Open slowly, close slowly, from slow to fast
		232-239	Open
		240-247	Random strobe, from slow to fast
		248-255	Open
6	CW/WW strobe	0-7	Close
		8-15	Open
		16-131	Strobe, from slow to fast
		132-139	Open
		140-181	Slow opening and fast closing, from slow to fast
		182-189	Open
		190-231	Open slowly, close slowly, from slow to fast
		232-239	Open
		240-247	Random strobe, from slow to fast
		248-255	Open
7	RGB Strobe	0-7	Close
		8-15	Open
		16-131	Strobe, from slow to fast
		132-139	Open
		140-181	Slow opening and fast closing, from slow to fast
		182-189	Open
		190-231	Open slowly, close slowly, from slow to fast
		232-239	Open
		240-247	Random strobe, from slow to fast
		248-255	Open
8	function	0-29	No function
		30-39	Dimming curve: linear
		40-49	Dimming curve: square ratio
		50-59	Dimming curve: inverse square
		60-69	Dimming curve: S curve
		70-139	No function

		140-149	Y Reset
		150-159	Zoom reset
		160-199	No function
		200-209	ALL reset
		210-219	Dimming speed: fast
		220-229	Dimming speed: smooth
		230-255	No function
9	Main red	0-255	0-100%
10	Main green	0-255	0-100%
11	Main blue	0-255	0-100%
12	Main white	0-255	0-100%
...
45	Main red10	0-255	0-100%
46	Main green10	0-255	0-100%
47	Main blue10	0-255	0-100%
48	Main white10	0-255	0-100%
49	CW1	0-255	0-100%
50	WW1	0-255	0-100%
...	0-100%
95	CW24	0-255	0-100%
96	WW24	0-255	0-100%
97	Auxiliary light R	0-255	0-100%
98	Auxiliary light G	0-255	0-100%
99	Auxiliary light B	0-255	0-100%

108CH

CH	Function	DMX value	explain
1	Y	0-255	0-270°
2	Y fine	0-255	16bit
3	Zoom	0-255	0-100%
4	dimmer	0-255	0-100%
5	Main light strobe	0-7	Close
		8-15	Open
		16-131	Strobe, from slow to fast

		132-139	Open
		140-181	Slow opening and fast closing, from slow to fast
		182-189	Open
		190-231	Open slowly, close slowly, from slow to fast
		232-239	Open
		240-247	Random strobe, from slow to fast
		248-255	Open
6	CW/WW strobe	0-7	Close
		8-15	Open
		16-131	Strobe, from slow to fast
		132-139	Open
		140-181	Slow opening and fast closing, from slow to fast
		182-189	Open
		190-231	Open slowly, close slowly, from slow to fast
		232-239	Open
		240-247	Random strobe, from slow to fast
		248-255	Open
7	RGB Strobe	0-7	Close
		8-15	Open
		16-131	Strobe, from slow to fast
		132-139	Open
		140-181	Slow opening and fast closing, from slow to fast
		182-189	Open
		190-231	Open slowly, close slowly, from slow to fast
		232-239	Open
		240-247	Random strobe, from slow to fast
		248-255	Open
8	function	0-29	No function
		30-39	Dimming curve: linear
		40-49	Dimming curve: square ratio

		50-59	Dimming curve: inverse square
		60-69	Dimming curve: S curve
		70-139	No function
		140-149	Y Reset
		150-159	Zoom reset
		160-199	No function
		200-209	ALL reset
		210-219	Dimming speed: fast
		220-229	Dimming speed: smooth
		230-255	No function
9	Main red	0-255	0-100%
10	Main green	0-255	0-100%
11	Main blue	0-255	0-100%
12	Main white	0-255	0-100%
...
45	Main red10	0-255	0-100%
46	Main green10	0-255	0-100%
47	Main blue10	0-255	0-100%
48	Main white10	0-255	0-100%
49	CW1	0-255	0-100%
50	WW1	0-255	0-100%
...
71	CW12	0-255	0-100%
72	WW12	0-255	0-100%
73	Auxiliary light R1	0-255	0-100%
74	Auxiliary light G1	0-255	0-100%
75	Auxiliary light B1	0-255	0-100%
...
106	Auxiliary light R12	0-255	0-100%
107	Auxiliary light G12	0-255	0-100%
108	Auxiliary light B12	0-255	0-100%

168CH

CH	Function	DMX value	explain
1	Y	0-255	0-270°
2	Y fine	0-255	16bit
3	Zoom	0-255	0-100%
4	dimmer	0-255	0-100%
5	Main light strobe	0-7	Close
		8-15	Open
		16-131	Strobe, from slow to fast
		132-139	Open
		140-181	Slow opening and fast closing, from slow to fast
		182-189	Open
		190-231	Open slowly, close slowly, from slow to fast
		232-239	Open
		240-247	Random strobe, from slow to fast
		248-255	Open
6	CW/WW strobe	0-7	Close
		8-15	Open
		16-131	Strobe, from slow to fast
		132-139	Open
		140-181	Slow opening and fast closing, from slow to fast
		182-189	Open
		190-231	Open slowly, close slowly, from slow to fast
		232-239	Open
		240-247	Random strobe, from slow to fast
		248-255	Open
7	RGB Strobe	0-7	Close
		8-15	Open
		16-131	Strobe, from slow to fast
		132-139	Open
		140-181	Slow opening and fast closing, from slow to fast

		182-189	Open
		190-231	Open slowly, close slowly, from slow to fast
		232-239	Open
		240-247	Random strobe, from slow to fast
		248-255	Open
8	function	0-29	No function
		30-39	Dimming curve: linear
		40-49	Dimming curve: square ratio
		50-59	Dimming curve: inverse square
		60-69	Dimming curve: S curve
		70-139	No function
		140-149	Y Reset
		150-159	Zoom reset
		160-199	No function
		200-209	ALL reset
		210-219	Dimming speed: fast
		220-229	Dimming speed: smooth
		230-255	No function
9	Main red1	0-255	0-100%
10	Main green1	0-255	0-100%
11	Main blue1	0-255	0-100%
12	Main white1	0-255	0-100%
...
45	Main red10	0-255	0-100%
46	Main green10	0-255	0-100%
47	Main blue10	0-255	0-100%
48	Main white10	0-255	0-100%
49	CW1	0-255	0-100%
50	WW1	0-255	0-100%
...
95	CW24	0-255	0-100%
96	WW24	0-255	0-100%
97	Auxiliary light R1	0-255	0-100%

98	Auxiliary light G1	0-255	0-100%
99	Auxiliary light B1	0-255	0-100%
...	0-100%
166	Auxiliary light R24	0-255	0-100%
167	Auxiliary light G24	0-255	0-100%
168	Auxiliary light B24	0-255	0-100%

170CH

CH	Function	DMX value	explain
1	Y	0-255	0-270°
2	Y fine	0-255	16bit
3	Zoom	0-255	0-100%
4	dimmer	0-255	0-100%
5	CW/WW Dimmer	0-255	0-100%
6	Auxiliary light RGB Dim	0-255	0-100%
7	Main light strobe	0-7	Close
		8-15	Open
		16-131	Strobe, from slow to fast
		132-139	Open
		140-181	Slow opening and fast closing, from slow to fast
		182-189	Open
		190-231	Open slowly, close slowly, from slow to fast
		232-239	Open
		240-247	Random strobe, from slow to fast
		248-255	Open
8	CW/WW strobe	0-7	Close
		8-15	Open
		16-131	Strobe, from slow to fast

		132-139	Open
		140-181	Slow opening and fast closing, from slow to fast
		182-189	Open
		190-231	Open slowly, close slowly, from slow to fast
		232-239	Open
		240-247	Random strobe, from slow to fast
		248-255	Open
9	RGB Strobe	0-7	Close
		8-15	Open
		16-131	Strobe, from slow to fast
		132-139	Open
		140-181	Slow opening and fast closing, from slow to fast
		182-189	Open
		190-231	Open slowly, close slowly, from slow to fast
		232-239	Open
		240-247	Random strobe, from slow to fast
		248-255	Open
10	function	0-29	No function
		30-39	Dimming curve: linear
		40-49	Dimming curve: square ratio
		50-59	Dimming curve: inverse square
		60-69	Dimming curve: S curve
		70-139	No function
		140-149	Y Reset
		150-159	Zoom reset
		160-199	No function
		200-209	ALL reset
		210-219	Dimming speed: fast
		220-229	Dimming speed: smooth
		230-255	No function
11	Main red1	0-255	0-100%

12	Main green1	0-255	0-100%
13	Main blue1	0-255	0-100%
14	Main white1	0-255	0-100%
...
47	Main red10	0-255	0-100%
48	Main green10	0-255	0-100%
49	Main blue10	0-255	0-100%
50	Main white10	0-255	0-100%
51	CW1	0-255	0-100%
52	WW1	0-255	0-100%
...	0-100%
97	CW24	0-255	0-100%
98	WW24	0-255	0-100%
99	Auxiliary light R1	0-255	0-100%
100	Auxiliary light G1	0-255	0-100%
101	Auxiliary light B1	0-255	0-100%
...	0-100%
168	Auxiliary light R24	0-255	0-100%
169	Auxiliary light G24	0-255	0-100%
170	Auxiliary light B24	0-255	0-100%

9.To maintain the good condition of the product and extend its service life, we recommend routine cleaning of the product.

1. Clean the external and internal lenses of the product every week to prevent reduced light output due to lens dust accumulation.
2. Clean the fan every week.
3. Every three months, a professional electrical engineer conducts

a detailed circuit inspection of the product to ensure that the circuit contacts are in good condition to prevent aging caused by overheating.

We suggest regularly cleaning the product, please be careful not to use damp or burlap, and never use alcohol or solvents for cleaning.